

**S92 Double Acting/S93 Spring Return**

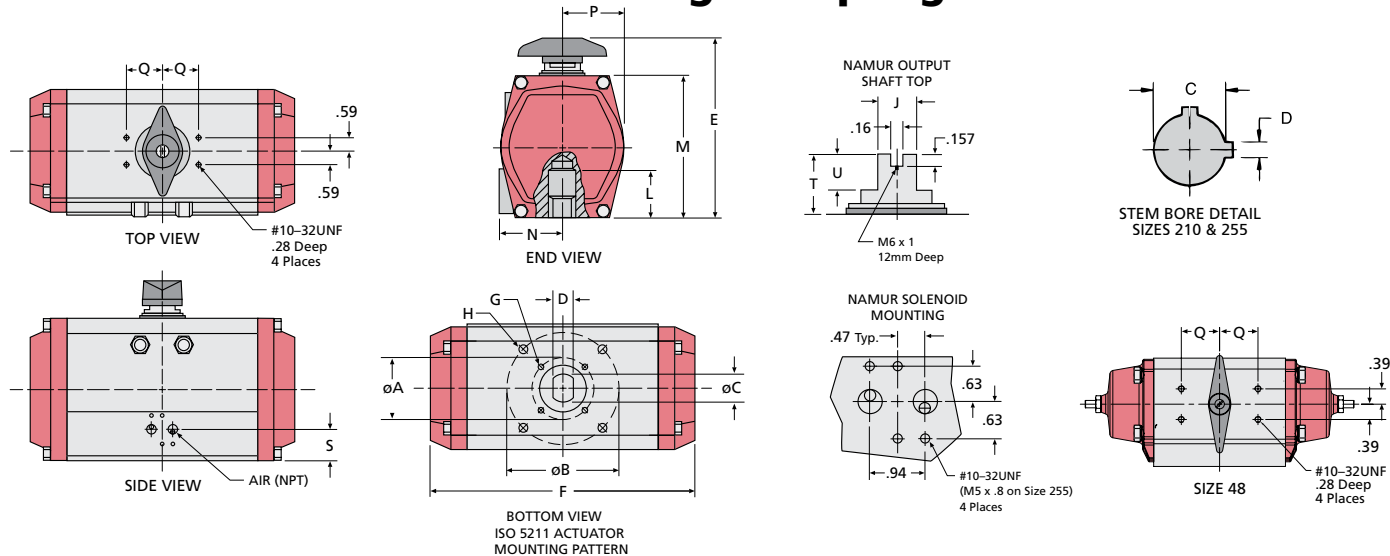

**IMPERIAL DIMENSIONS - Inches**

Size	48	63	83	92	119	127	160*	210	255‡
Air NPT	1/8	1/4	1/4	1/4	1/4	1/4	1/4	1/4	1/4
A ISO "F"†	1.42 - F 03	1.97 - F 05	1.97 - F 05	1.97 - F 05	2.76 - F 07	2.76 - F 07	—	4.92 - F 12	6.50 - F 16
B ISO "F"†	1.97 - F 05	2.76 - F 07	2.76 - F 07	2.76 - F 07	4.92 - F 12	4.92 - F 12	4.92 - F 12	6.50 - F 16	7.87x4.72 Rect.
C	.55	.55	.75	.75	1.18	1.18	1.18	1.97	2.50
D	.40	.40	.51	.51	.87	.87	.87	.47	.62
E	3.88	4.53	5.43	5.78	7.28	8.09	9.36	11.62	13.49
F	4.38	5.58	7.40	8.59	12.40	12.31	15.54	19.57	28.78
G (UNC)	10-32 x .23	1/4-20 x .32	1/4-20 x .32	1/4-20 x .32	5/16-18 x .46	5/16-18 x .46	—	1/2-13 x .78	M16x2 x 28mm
H (UNC)	1/4-20 x .25	5/16-18 x .40	5/16-18 x .40	5/16-18 x .40	1/2-13 x .69	1/2-13 x .69	1/2-13 x .75	5/8-11 x 1.11	M16x2 x 28mm
J	.38	.38	.50	.50	1.12	1.12	1.12	1.12	1.12
L	1.38	1.38	1.46	1.46	2.20	2.20	2.20	4.72	6.50
M	2.50	3.46	4.27	4.61	5.52	6.32	7.80	10.16	12.06
N	1.60	1.72	2.28	2.47	2.78	2.88	3.78	4.56	5.40
P	1.18	1.38	1.79	1.97	2.37	2.70	3.39	4.41	5.39
Q	.98	1.58	1.58	1.58	1.58	1.58	2.56	2.56	2.56
R	1.25	.89	1.26	1.32	1.64	1.64	2.26	2.45	2.48
S	1.10**	.79	.79	.79	.79	.79	1.18	1.18	1.18
U	.47	.47	.47	.47	.47	.47	.75	.75	.75

**Note:** Double Acting and Spring Return actuators have the same overall dimensions.  
 The double acting unit of the size 48 actuator is optionally available with flat end caps with an F dimension of 4.00  
 † ISO "F" means mounting flange-drilling pattern.  
 \* Dimensions for Size 160A in table. Size 160B (keyed stem version) has C dimension of 1.38 and D dimension of .39  
 ‡ Dimensions for Size 255A in table. Size 255B actuator has a C dimension of 3.00 and D dimension of .75  
 \*\* Size 48 has a T dimension of .79 with use of NAMUR top plate.

**WEIGHTS - lbs** - Spring Return unit weights are with full set of springs on each piston.

Size	48	63	83	92	119	127	160	210	255
Double Acting	2.0	3.4	6.3	8.5	16.9	21.0	38.8	77.8	167.0
Spring Return	2.4	4.10	8.1	10.8	22.3	27.6	53.2	109.6	210.8

Drawings are for reference only. Please refer to Bray ES drawings on the Bray website, www.bray.com. Bray reserves the right to change product dimensions without notice.

**SR Drawing #92-93-i** August 2012- Rev. 0

Customer/Project: \_\_\_\_\_

Inquire/P.O. No.: \_\_\_\_\_

Bray Order No.: \_\_\_\_\_

**S92 Double Acting/S93 Spring Return**

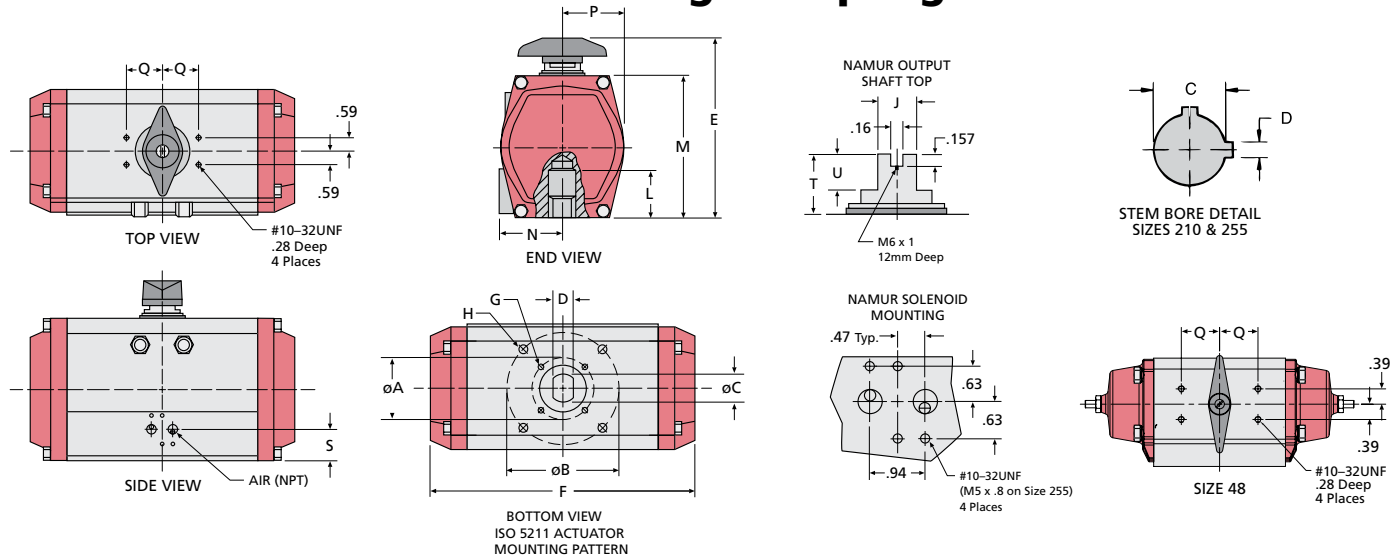

**METRIC DIMENSIONS - Millimeters**

Size	48	63	83	92	119	127	160*	210	255‡
Air NPT	1/8	1/4	1/4	1/4	1/4	1/4	1/4	1/4	1/4
A ISO "F"†	36 - F 03	50 - F 05	50 - F 05	50 - F 05	70 - F 07	70 - F 07	—	125 - F 12	165 - F 16
B ISO "F"†	50 - F 05	70 - F 07	70 - F 07	70 - F 07	125 - F 12	125 - F 12	125 - F 12	165 - F 16	200 x 120 Rect.
C	14	14	19	19	30	30	30	50	64
D	10	10	13	13	22	22	22	12	16
E	99	115	138	147	185	205	238	295	343
F	111	142	188	218	315	313	395	497	731
G (UNC)	10-32 x .23	1/4-20 x .32	1/4-20 x .32	1/4-20 x .32	5/16-18 x .46	5/16-18 x .46	—	1/2-13 x .78	M16x2 x 28mm
H (UNC)	1/4-20 x .25	5/16-18 x .40	5/16-18 x .40	5/16-18 x .40	1/2-13 x .69	1/2-13 x .69	1/2-13 x .75	5/8-11 x 1.11	M16x2 x 28mm
J	10	10	13	13	28	28	28	28	28
L	35	35	37	37	56	56	56	120	165
M	64	88	108	117	140	161	198	258	306
N	41	44	58	63	71	73	96	116	137
P	30	35	45	50	60	69	86	112	137
Q	25	40	40	40	40	40	65	65	65
R	32	23	32	34	42	42	57	62	63
S	28**	20	20	20	20	20	30	30	30
U	12	12	12	12	12	12	19	19	19

**Note:** Double Acting and Spring Return actuators have the same overall dimensions.

The double acting unit of the size 48 actuator is optionally available with flat end caps with an F dimension of 102mm  
 † ISO "F" means mounting flange-drilling pattern.

\* Dimensions for Size 160A in table. Size 160B (keyed stem version) has C dimension of 35mm and D dimension of 10mm

‡ Dimensions for Size 255A in table. Size 255B actuator has a C dimension of 76mm and D dimension of 19mm

\*\* Size 48 has a T dimension of 20mm with use of NAMUR top plate.

**WEIGHTS - Kilograms - Spring Return unit weights are with full set of springs on each piston.**

Size	48	63	83	92	119	127	160	210	255
Double Acting	0.9	1.5	3	4	8	10	18	35	76
Spring Return	1.1	1.9	4	5	10	13	24	50	96

Drawings are for reference only. Please refer to Bray ES drawings on the Bray website, www.bray.com. Bray reserves the right to change product dimensions without notice.

**SR Drawing #92-93-m** August 2012- Rev. 0

Customer/Project: \_\_\_\_\_

Inquire/P.O. No.: \_\_\_\_\_

Bray Order No.: \_\_\_\_\_