

Specification Sheet

Industrial Positive Displacement Meter Model C700 Bronze, Magnetic Drive, External Threaded Spuds



Size: 3/4" x 3/4", 3/4" x 3/4"S & 3/4" x 1"

Description

Operation. The C700 is an oscillating piston style, positive displacement water meter. The product utilizes a piston that water use rotates in a measuring chamber, each piston revolution being equivalent to a known volume of water. The piston movement is transferred by a magnetic drive to a straight reading sealed register which contains the appropriate reduction gearing.

Compliance to Standards. The C700 fully complies with American Water Works Association Standard C700, latest revision, and is California Department of Weights and Measures approved.

Installation. The meter must be installed in a clean pipeline, free from any foreign materials. Install the meter with direction of flow as indicated by the arrow cast in the meter case. The meter may be installed in horizontal, vertical or inclined lines, with register facing upward.

Application. The meter is for use only with POTABLE COLD WATER up to 120°F (50°C) and working pressures up to 150 psi. The meter will register between 98.5% and 101.5% at normal and high flows and between 97% and 101% at the AWWA specified low flow. Accuracy tests are made before shipment, so no adjustments need to be made before installation.

Construction. The meter consists of a straight through-flow main case, dual inlet measuring chamber, vertically grooved oscillating piston, high capacity strainer, removable bottom plate, full rubber liner, body bolts with integral washers and a magnetically driven register. The main case is cast in bronze with raised characters designating model, size and direction of flow. A choice of polymer, cast iron or bronze bottom plate is available. The 2-piece snap-fit measuring chamber is of a top and bottom inlet, side output design and features a unique self-flushing sediment well. Other features include a removable, contoured division plate, captive drive bar and high torque magnet complete with a nylon bushing. The flow-stream balanced piston has a

Specifications

| Sizes: | 3/4" x 3/4" | 3/4" x 3/4"S | 3/4" x 1" |
|---------------------------|-------------|--------------|-----------|
| 95%-101% Accuracy GPM | 1/4 | 1/4 | 1/4 |
| 97% - 101% Accuracy GPM | 1/2 | 1/2 | 1/2 |
| 98.5%-101.5% Accuracy GPM | 2-30 | 2-30 | 2-30 |
| Continuous Flow GPM | 15 | 15 | 15 |
| Maximum Flow GPM | 30 | 30 | 30 |
| Operating Pressure psi | 150 | 150 | 150 |
| Operating Temperature °F | 120 | 120 | 120 |

Sweep Hand Registers:

| | | | |
|-----------------------|-------|-------|-------|
| US Gallons | 10 | 10 | 10 |
| Cubic Feet | 1 | 1 | 1 |
| Cubic Meters (Canada) | 1/10 | 1/10 | 1/10 |
| Cubic Meters (Intl.) | 1/100 | 1/100 | 1/100 |

Capacity of Register (millions):

| | | | |
|-----------------------|------|------|------|
| US Gallons | 10 | 10 | 10 |
| Cubic Feet | 1 | 1 | 1 |
| Cubic Meters (Canada) | 1/10 | 1/10 | 1/10 |
| Cubic Meters (Intl.) | 1/10 | 1/10 | 1/10 |

Register Type:

Permanently sealed direct reading

Materials:

| | |
|--------------------------|--|
| Main Case | Bronze |
| Bottom Plate Options | Bronze, Cast Iron or Synthetic Polymer |
| Bottom Gasket-Liner | Nitrile |
| Body Bolts | Stainless Steel |
| Measuring Chamber | Compounded Polymer |
| Division Plate | Loaded Nylon |
| Piston | High Impact Polymer |
| Thrust Bearing Insert | Loaded Nylon |
| Driving Bar | Loaded Nylon |
| Strainer | Polypropylene |
| Register Can | 90% Copper Alloy |
| Register Lens | Tempered Glass |
| Register Housing and Lid | Polymer or Bronze |

unique thrust bearing insert and features a Turbulence Seal™ system which passes debris while sustaining the most linear accuracy curve in the industry. Each register is secured to the main case with a tamper-proof plug to eliminate tampering.

Direct Read Register. The register is contained within a 90% copper seamless can which is oven-cured at 150°F for 90 minutes to eliminate condensation. The 5 mm true tempered glass lens is secured with an "L" shaped gasket, then roll sealed to produce a permanently sealed design. To assure easy reading, the totalizer wheels are large and color coded. The applicable size, model, registration, part number and date code are printed on the calibrated dial face. Moving clockwise during operation, the extra-thin center sweep hand does not interfere with meter reading, and the 1:1 piston ratio low-flow indicator gives visual indication of plumbing leaks. For accurate meter testing, 100 clear graduations appear at the register's circumference.

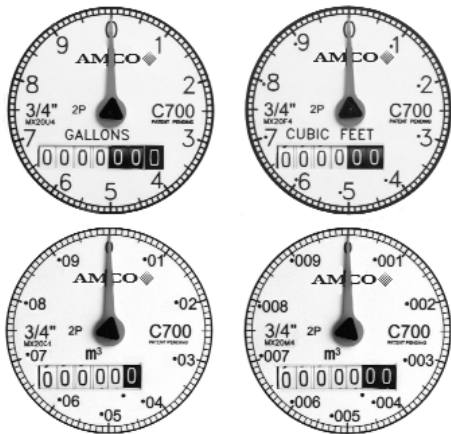

Magnetic Drive. The magnetic drive design facilitates coupling between the measuring chamber and the external register. The coupling is absolute at all rated flows.

Connections. Meter casing spuds have external straight threads conforming to ANSI B2.1. Bronze coupling nuts and tailpieces are available. Tailpieces have external taper pipe threads conforming to ANSI B2.1. Their lengths and thread sizes are as specified by AWWA Standards.

Maintenance. The measuring chamber assembly can be removed, repaired or replaced. Pretested measuring chamber assemblies are available for exchange or purchase, and spare parts are available from our central warehouse or designated regional locations. AMCO Water staffs and operates a repair facility at its U.S. manufacturing plant in Ocala, Florida.

Pulsar Type "BI". The "BI" pulsar is a limit switch device which requires power from an external source (2 wire). Contact closure: 1 contact = 1 USG. The switch is rated to 3 amps at 125 VAC max. Note: Register housing and register are 3½ in. diameter style. For full details see specification sheet INDC7-PUL-001.

Pulsar Type "SFI". The "SFI" pulsar is a solid state device which requires 6-24 VDC from an external source (3 wire). Note: Register housing and register are 3½ in. diameter style. Contact closure:

| | | |
|--------------|-------------------|---------------------|
| 3/4" x 3/4" | 66.6cont/USG Std. | 133.2 cont/USG Opt. |
| 3/4" x 3/4"S | 66.6cont/USG Std. | 133.2 cont/USG Opt. |
| 3/4" x 1" | 66.6cont/USG Std. | 133.2 cont/USG Opt. |

For full details see specification sheet INDC7-PUL-001.

Dimensions and Net Weights

| Meter Size | Dimensions (inches) | | | | | | Weight (lbs.) |
|--------------|---------------------|--------|--------|-------|-------|-------|---------------|
| | A | B | C | D | E | F | |
| 3/4" x 3/4"S | 7 1/2 | 6 3/16 | 2 1/16 | 3 7/8 | 9 1/2 | 3 3/4 | 4 3/5 |
| 3/4" x 3/4" | 9 | 6 3/16 | 2 1/16 | 3 7/8 | 9 1/2 | 3 3/4 | 4 4/5 |
| 3/4" x 1" | 9 | 6 3/16 | 2 1/16 | 3 7/8 | 9 1/2 | 3 3/4 | 4 4/5 |

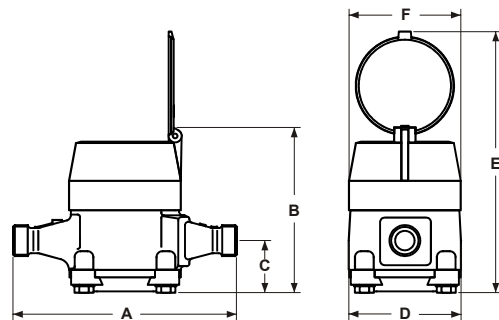

AMCO Water Metering Systems Inc.

www.amcowater.com

United States - ISO 9002 Registered
 AMCO Water Metering Systems
 P. O. Box 1852
 Ocala, FL 34478-1852
 352-732-4670 FAX 352-368-1950
 Outside Florida: 800-874-0890
 Inside Florida: 800-356-6829
 e-mail:
 watermeters@amcowater.com

Canada
 Elster Metering
 3450 Harvester Road
 Burlington, Ontario L7N 3W5
 866-703-7582
 905-634-4895
 FAX 905-634-6705
 e-mail:
 watermeters@ca.elster.com

Caribbean
 AMCO Water Metering Systems
 P. O. Box 225
 Carretera 112 KM 2.3
 Isabela, PR 00662
 787-872-2006
 FAX 787-872-5427
 e-mail:
 prwatermeters@amcowater.com

Mexico
 Elster Medidores
 Lago Omega #281
 Col. Modelo Pensil.
 Del. Miguel Hidalgo
 C P 11460
 525 55 203 8002
 FAX 525 55 203 8270
 e-mail:
 amcowater@prodigy.net.mx

The company's policy is one of continuous product improvement and the right is reserved to modify the specifications contained herein without notice.

©2003 AMCO Water Metering Systems Inc. All rights reserved.

IND-C700-34/02-03